

Operating Instructions for Actuators Type exCM12 and exCM25

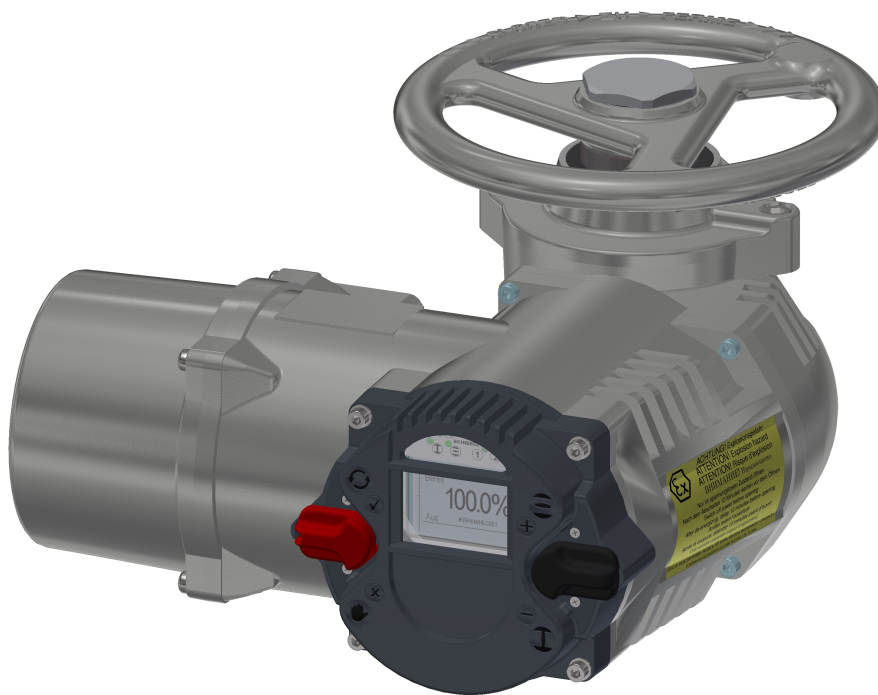

Contents

Contents	2
Hazard Warnings	3
Operating Instructions for Actuators Type exCM12 and exCM25	4
1 Introduction/Notes	4
2 General	5
2.1 Overview	5
2.2 Model Code	6
2.3 Serial number and type label	6
2.4 Operating mode	7
2.5 Protection class	7
2.6 Mounting position	7
2.7 Direction of rotation	7
2.8 Protection devices	8
2.8.1 Torque	8
2.8.2 Motor temperature	8
2.8.3 Input fuse, thermal fuse	8
2.9 Ambient temperature	9
2.10 Delivery condition of the actuators	9
2.11 Information notice (tag)	9
3 Packaging, transport and storage	10
3.1 General	10
3.2 Storage	10
3.3 Long-term storage	10
4 Installation instructions	11
4.1 Mechanical connection	12
4.2 Mounting position of the operating unit	12
4.3 Electrical connection	14
4.3.1 Power supply connection	14
5 Commissioning	15
5.1 General	15
5.2 Manual operation	16
5.3 Mechanical default settings, preparation	16
5.4 Welcome Menu	16
5.5 User Level and Permissions	17
5.6 End limit setting	17
5.6.1 End limit OPEN	18
5.6.2 End limit CLOSE	21
5.7 Final works	21
6 Maintenance	22
7 Battery Replacement	24
8 Troubleshooting	25
9 Fuses	25
10 Spare parts	26
11 Lubricant recommendation, lubricant requirements	26
11.1 Main body: -25 to +70 °C	26
11.2 Main body: -40 to +70 °C	26
11.3 Output type A, spindle drives (linear actuators) and Failsafe actuators: -20 to +70 °C	26
11.4 Output type A, spindle drives (linear actuators) and Failsafe actuators: -40 to +70 °C	27
11.5 Basic lubricant service interval	27

12 Training	27
13 Original Declaration of Incorporation of Partly Completed Machinery	28
14 Declaration of Conformity	29
15 Technical data	31
15.1 Binary outputs	31
15.2 Binary inputs	31
15.3 Analog inputs	33
15.4 Analog output	34
15.5 Auxiliary voltage input and output	35
15.6 Connections	35
15.6.1 Connections for non explosion-proof version	35
15.6.2 Connections for explosion-proof version	35
15.7 Miscellaneous	36
16 Technical data CM12	36
16.1 Standard version CM12	36
17 Technical data CM25	36
17.1 Standard version CM25	36
18 Characteristic curves	37
18.1 Characteristic curves - CM12	37
Spare parts ACTUSMART (ex)(r)CM12.V1.2	38

Hazard Warnings

Hazard warnings in this manual indicate potential harm to the user or the product. For the person interacting with the product, the level of risk includes consequences ranging from slight, up to lethal injuries. As for the product, disobeying the warnings may cause damage to the equipment and/or void the warranty. Therefore, said warnings are made apparent to instruct and warn the user, which precautions have to be made prior to performing any actions described in this manual. The user must read and be familiar with the manual, before performing any tasks as described in this manual.

Hazard warnings in this manual are presented in these three forms:

WARNING: These warning notices refer to personal safety. Failure to obey these notices could result in personal injury or death.



WARNING

CAUTION: General precautions must be made. Failure to obey these notices could result in personal injury and/or equipment damage.



CAUTION

NOTE: Directs the user's attention to essential information.

Operating Instructions for Actuators Type exCM12 and exCM25

1 Introduction/Notes

These operating instructions apply to SCHIEBEL actuators of the ACTUSMART CM series. The scope of application covers the operation of industrial valves, e.g., globe valves, gate valves, butterfly valves and ball valves. For other applications please consult with the factory. The manufacturer shall not be liable for incorrect use and possible damage arising thereof. The risk shall be borne solely by the user.

NOTE: Using the unit as intended also entails the observance of these operating instructions!

WARNING: When operating electrical equipment, certain parts inevitably carry hazardous voltage levels. Work on the electrical system or equipment must be carried out only in accordance with electrical regulations by a qualified electrician or by specially instructed personnel under the control and supervision of a qualified electrician.



WARNING

CAUTION: Maintenance instructions must be observed as otherwise the safe operation of the actuator cannot be guaranteed.



CAUTION

WARNING: Failure to follow the warning information may result in serious bodily injury or property damage. Qualified personnel must be thoroughly familiar with all warnings contained in this operating manual.



WARNING

CAUTION: Proper transport, storage, installation, assembly and careful commissioning are essential for proper and safe operation.



CAUTION

WARNING: When working in potentially explosive areas, observe the European Standards EN 60079-14 "Electrical Installations in Hazardous Areas" and EN 60079-17 "Inspection and Maintenance of Electrical Installations in Hazardous Areas".



WARNING

WARNING: Maintenance work on open actuators may only be conducted if these are de-energized. Reconnection during maintenance is strictly prohibited.



WARNING

WARNING: The actuator shall not be installed in areas of strongly charge generating processes. In addition, the equipment shall only be cleaned with an antistatic or damp cloth.



WARNING

2 General

The actuator of the ACTUSMART CM series is a compact rotary actuator with integrated controller for valve operation. The integral multi-turn sensor allows setting the travel up to 1600 revolutions without opening the housing.

2.1 Overview

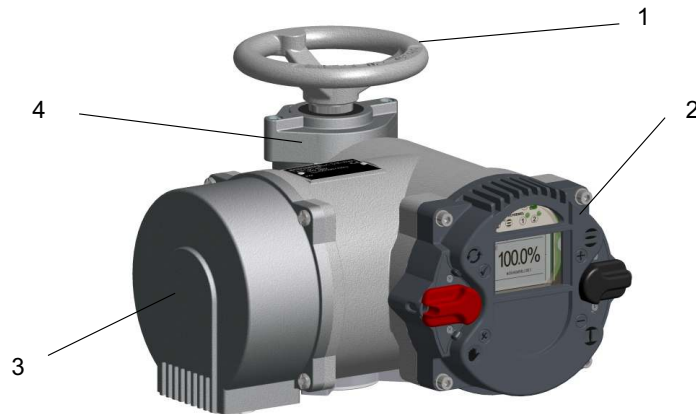

Figure 1: 1... Handwheel, 2... Control unit (operating unit), 3... Connection compartment 4... Gear component

2.2 Model Code

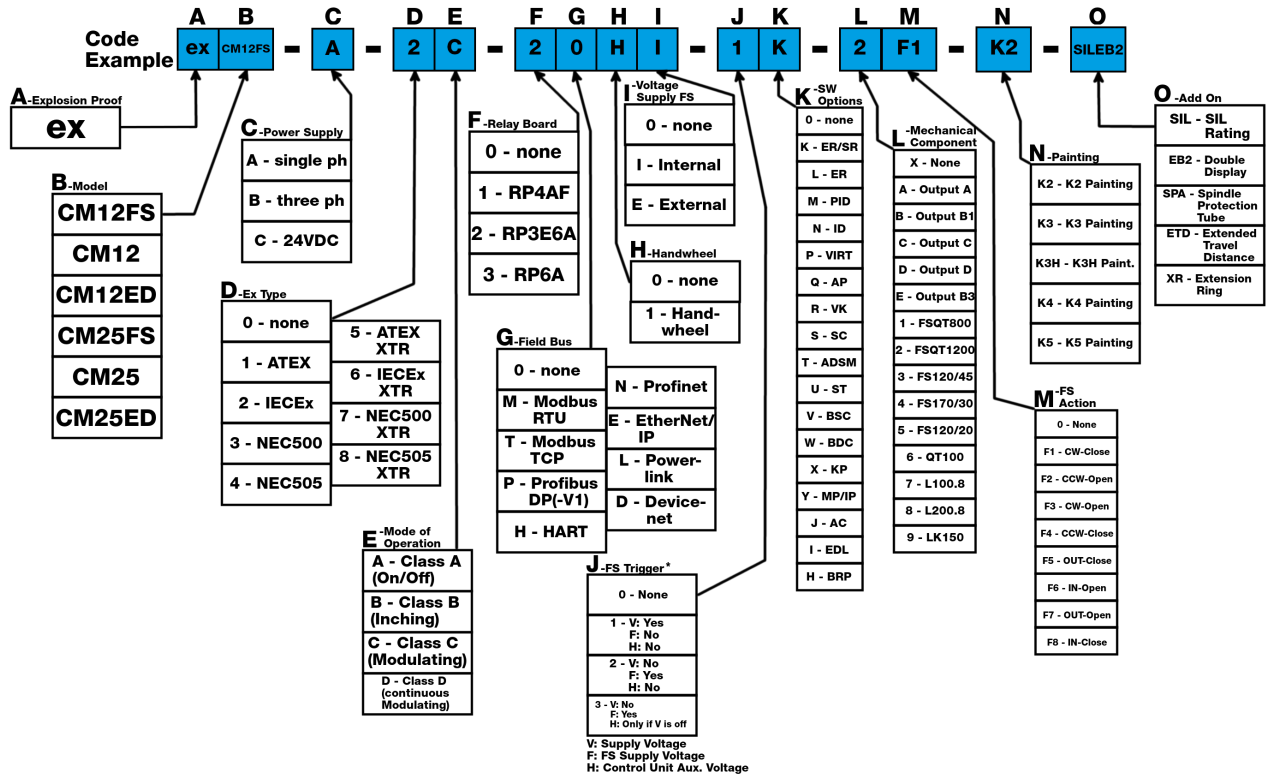

Figure 2: Model Code for (ex)CM series actuators

2.3 Serial number and type label

Each actuator of the ACTUSMART CM series carries a serial number. The serial number is a 10-digit number that begins with the year and that can be read from the type label (see Figure 3) of the actuator (the type label is located next to the handwheel – see Figure 4).

Using this serial number, SCHIEBEL can uniquely identify the actuator (type, size, design, options, technical data and test report).

No.: 21115 00035
 Type: CM12FS-A-0C
 Opt: 200E-1K-2F1-K2-SILEB2
 Close: 30,0-125Nm
 Open: 30,0-125Nm
 Stw.: 100revs. Stz.: 100-2400sec
 n: 1,0-70,0rpm Sa: IP67

SCHIEBEL

1022
2023

In: 3,80A/230VAC
 Pn: 0,65kW
 Ba: S2-15min
 U/f: 1x110-240VAC 50-60Hz
 SCC 10.11.07_1+SCP 12.40.06_2
 Josef Benc Gasse 4, 1230 Vienna, Austria

Tamb: -40°C...+60°C

210297/2

Figure 3: Type label



Figure 4: 1... Type label

NOTE: Actuators which are suitable for operation in explosive atmosphere (see EU Directive 2014/34/EG and EN 60079-0 Standard) are separately designated by a special type label (Ex, TÜV Standard, Figure 5).

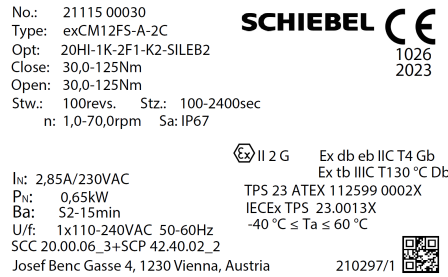

Figure 5: Type label of the actuator for operation in explosive atmosphere

2.4 Operating mode

ACTUSMART exCM12 and exCM25 actuators are suitable for open-loop control (S2 operating mode – on/off duty) and closed-loop control (S4 operating mode – modulating duty) according to EN 60034-1, as well as for operating modes class A, B, C acc. DIN EN 22153.

2.5 Protection class

ACTUSMART CM actuators by default meet IP 67 (EN 50629) protection.

CAUTION: The protection class specified on the type label is only effective when the cable glands also provide the required protection class, the cover of the connection compartment is carefully screwed closed, and the mounting position (see section 2.6, page 7) is observed.



We recommend metallic screwed cable glands with a metrical thread. Furthermore, cable inlets that are not needed must be closed with screw plugs.

CAUTION: On explosion-proof actuators, cable glands with protection class **Ex e acc. EN 60079-7** must be used. **After removing covers** for assembly purposes or adjustment work, take special care upon reassembly so that seals are not damaged and remain properly fastened. Improper assembly may lead to water ingress and to failures of the actuator.



NOTE: Allow a certain sag in the connector cables before reaching the screwed cable glands so that water can drip off from the connector cables without running to the screwed cable glands. This way, forces acting on the screwed cable glands are also reduced (see section 2.6).

2.6 Mounting position

Generally, the installation position is irrelevant. However, based on practical experience, it is advisable to consider the following for outdoors use or in splash zones:

- Mount actuators with cable inlet facing downwards.
- Ensure that sufficient cable slack is available.

2.7 Direction of rotation

Unless specifically ordered otherwise, the standard direction is (see Figure 6 and Figure 7):

- **right turning (clockwise) = CLOSING**
- **left turning (counter-clockwise) = OPENING**

Clockwise rotation of the actuator is given when the output shaft turns counter clockwise when looking at the output shaft.

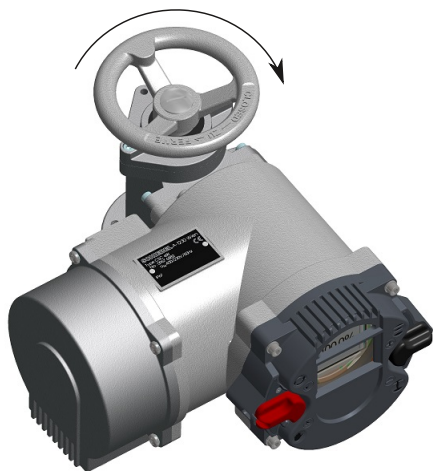

Figure 6: clockwise = close

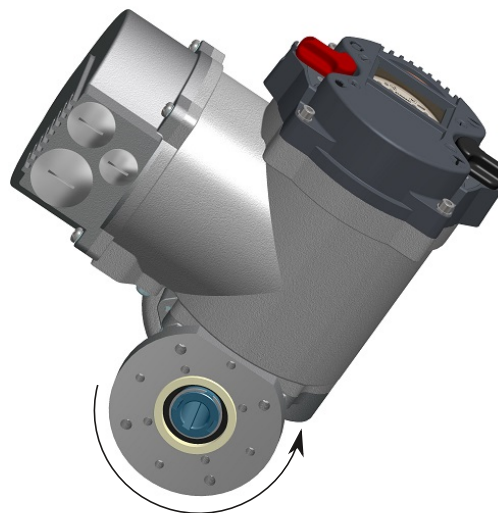

Figure 7: counter-clockwise = close

NOTE: All specifications in this operating manual refer to the standard direction of rotation.

2.8 Protection devices

2.8.1 Torque

ACTUSMART actuators provide electronic torque monitoring.

The switch-off torque can be modified in the controller menu for each direction separately. By default, switch-off torque is set to the ordered value. If no torque was specified with the order, the actuator is supplied from the factory with the maximum configurable torque.

For more information, see *Operating Instructions for ACTUSMART Control Units*, section *Parameter group: Torque*.

2.8.2 Motor temperature

All ACTUSMART CM actuators are normally equipped with motor winding temperature sensors, which protect the motor against excessive winding temperature.

The display will show the corresponding error upon exceeding the permissible motor temperature (see *Operating Instructions for ACTUSMART Control Units*, section *History Entries*).

2.8.3 Input fuse, thermal fuse

The frequency inverter has an input fuse and, in the case of explosion-proof versions, also a thermal fuse. If one of these fuses trips, there is a serious fault. The frequency converter is permanently disconnected from the supply and must be replaced.

Depending on the actuator type, the following input fuses are used:

Actuator Type	Supply Voltage	Current Rating
(ex)CM12	1x110...240VAC	10AT
exCM12	3x380...480VAC	10AT
(ex)CM25	1x110...240VAC	10AT
exCM25	3x380...480VAC	10AT

NOTE: Ceramic tube, 5mm x 20mm time-delay fuses acc. to IEC 60127-2 shall be used for replacement.

2.9 Ambient temperature

Unless otherwise specified upon ordering, the following operating temperatures apply:

- On/off duty (open-loop control) -25 ... +60 °C
- Modulating duty (closed-loop control) -25 ... +60 °C
- explosion-proof version -20 ... +40 °C (acc. EN 60079-0)
- explosion-proof version with extended temperature range -40 ... +70 °C
- exCM12 Failsafe actuators with extended temperature range -40 ... +60 °C

CAUTION: The maximum operating temperature can also depend on further order-specific components. Please refer to the technical data sheets to confirm the as-delivered product specifications.



2.10 Delivery condition of the actuators

For each actuator, an inspection report is generated upon final inspection. In particular, this comprises a full visual inspection, calibration of the torque measurement in connection with an extensive run examination and a functional test of the micro controllers.

These inspections are conducted and documented according to the quality system and can be made available if necessary.

The basic setting of the end position must be performed after assembly on the actuator.

CAUTION: Commissioning instructions (see section 5, page 15) must be strictly observed!

During assembly of the supplied valves at the factory, end positions are set and documented by attaching a label (see Figure 8). During commissioning at the plant, these settings must be verified.

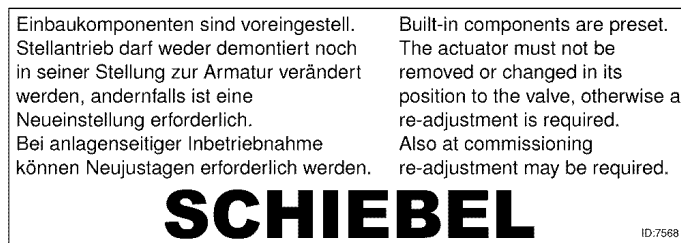

Figure 8: Label

2.11 Information notice (tag)

Each actuator is provided with a bilingual tag containing key information, which is attached to the handwheel after final inspection. This tag also shows the internal commission registration number (see Figure 9, page 10).

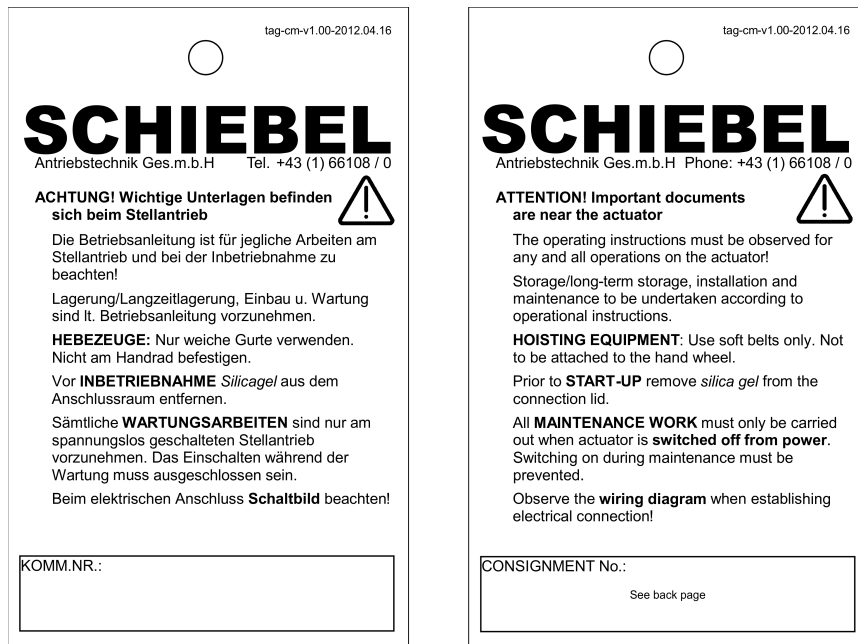

Figure 9: Tag

3 Packaging, transport and storage

Depending on the order, actuators may be delivered packed or unpacked. Special packaging requirements must be specified when ordering. Please use extreme care when removing or repackaging equipment.

CAUTION: Use soft straps to hoist the equipment; do not attach straps to the handwheel. If the actuator is mounted on a valve, attach the hoist to the valve and not to the actuator.



3.1 General

The connection compartment of ACTUSMART CM actuators contains 5 g of factory supplied silica gel.

NOTE: Please remove the silica gel before commissioning the actuator (see section 5, page 15).

3.2 Storage

NOTE: Please observe the following measures to avoid damage during the storage of actuators:

- Store actuators in well-ventilated, dry premises.
- Protect against floor dampness by storing actuators on wooden grating, pallets, mesh boxes or shelves.
- Protect the actuators against dust and dirt with plastic foil.
- Actuators must be protected against mechanical damage.
- The storage temperature must be between -20 °C and +40 °C.

It is not necessary to open the controller of the actuator for servicing batteries or similar operations.

3.3 Long-term storage

NOTE: If you intend to store the actuator for more than 6 months, additionally follow the instructions below:

4 Installation instructions

- The silica gel in the connection compartment must be **replaced after 6 months** of storage (from date of delivery from SCHIEBEL's factory in Vienna).
- After replacing the silica gel, brush the connection cover seal with glycerine. Then, carefully close the connection compartment again.
- Coat screw heads and bare spots with neutral grease or long-term corrosion protection.
- Amend damaged paintwork arising from transport, improper storage, or mechanical influences.
- Every 6 months, all measures and precautions for long-term storage must be checked for effectiveness, and corrosion protection and silica gel must be renewed.

NOTE: Failure to follow the instructions above may lead to condensation which can damage the actuator.

4 Installation instructions



Figure 10: 1... mounting flange, 2... bore pattern G0/F10, 3... centring ring, 4... bore pattern F07, 5... shaft connection, 6... ground connection

Installation work of any kind on the actuator may only be performed by qualified personnel.

WARNING: When working in potentially explosive areas, observe the European Standards EN 60079-14 "Electrical Installations in Hazardous Areas" and EN 60079-17 "Inspection and Maintenance of Electrical Installations in Hazardous Areas".



WARNING

WARNING: The actuator shall not be installed in areas of strongly charge generating processes (see explosion protection sticker on figure 34 on page 22). In addition, the equipment shall only be cleaned with an antistatic or damp cloth.



WARNING

4.1 Mechanical connection

see Figure 10, page 11

Check whether the valve flange, actuator flange and valve shaft correspond to the shaft connector of the actuator. For output type "Am" (threaded bushing with bore), check whether the thread of the valve matches the thread of the actuator.

In general, proceed as follows:

- Clean the bare parts of the actuator uncoated with corrosion protection.
- Thoroughly clean the screw mounting surfaces of the valve.
- In the actuator, appropriately lubricate the output shaft and the valve of the driven shaft.
- In the "Am" version, ensure that the valve bushing is amply lubricated.
- Attach the actuator to the valve or gearbox.
- Tighten fastening screws (torque according to table below).
- By means of the handwheel, check the ease of movement of the actuator-valve connection.

Thread	Tightening [Nm] for screws with strength class	
	8.8	A2-70 / A4-70
M6	11	8
M8	25	18
M10	51	36
M12	87	61
M16	214	150
M20	431	294
M30	1489	564

NOTE: For output type A (unbored threaded bushing), you must sufficiently lubricate both needle bearings in the output form after processing and cleaning the spindle nut.

For this purpose, use the optional SCHIEBEL grease lubricant or a grease lubricant according to our recommendation (see section 11.3, page 26).

4.2 Mounting position of the operating unit

The mounting position of the operating unit can be rotated in 90° steps.

WARNING: The control unit must not be opened when an explosive gas atmosphere is present.



WARNING

WARNING: Certain parts of the actuator carry hazardous voltage levels. Work on open actuators may only be conducted if these are de-energized. Reconnection during maintenance is strictly prohibited.



WARNING

CAUTION: During installation, the position of the operating unit in relation to direct sunlight must be observed. It is recommended to protect the unit from direct sunlight (roof, installation position) to avoid possible malfunctions.



CAUTION

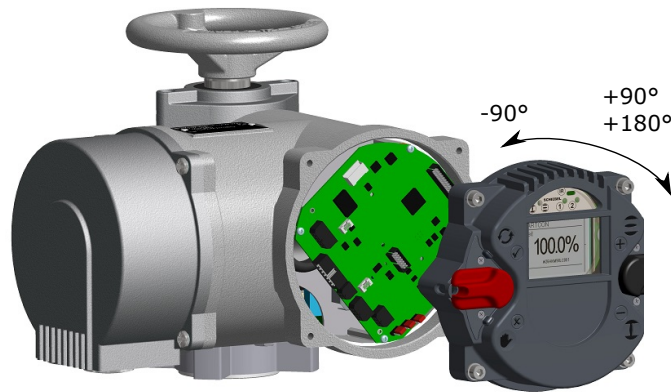

Figure 11

- Disconnect the actuator and control system from the power supply.
- To prevent damage to the electronic components, both the control system and the person have to be earthed!
- Unscrew the bolts for the interface surface and carefully remove the operating unit cover.
- Turn operating unit cover to new position and put back on.
 - Ensure correct position of the O-ring.
 - Turn operating unit cover by max. of 180°.
 - Put operating unit cover on carefully so that no cables get wedged in.
- Screw the bolts shut evenly in a crosswise sequence. **IMPORTANT:** max. torque 5 Nm

CAUTION: For explosion-proof actuators, care must be taken for the flameproof joints. Avoid tilting of the control unit cover upon removal and reassembly to prevent damage on the gap surfaces.



CAUTION

CAUTION: In the case of explosion-proof actuators, repairs to the flameproof joints are **NOT** intended. If damage is found on the gap surfaces, the device must be replaced!



CAUTION

4.3 Electrical connection

WARNING: Hazardous voltage! Electrical connections may only be carried out by qualified personnel. Please observe all relevant national security requirements, guidelines, and regulations.



WARNING

Please check the steps below upon connecting the actuator.

- The equipment should be de-energized before working on electrical connections.
- Confirm the absence of electrostatic discharges during the connection.
- Connect the ground screw first.
- The line and short circuit protection must be done on the system side.
- The ability to unlock the actuator for maintenance purposes must be provided.
- For the dimensioning, the rated current is to be used (see Technical Data).
- Check whether the power supply (voltage, frequency) is consistent with the connection data (see type label – Figure 3, page 6)
- The connection of electrical wiring must follow the circuit diagram. This can be found in the appendix of the documentation. The circuit diagram can be ordered from SCHIEBEL by specifying the serial number.

NOTE: When using options, such as a Profibus connection, the relevant guidelines must be followed.

4.3.1 Power supply connection

ACTUSMART CM actuators feature an integrated motor controller, i.e. only a connection to the power supply is required.

In **non explosion-proof actuators**, the wiring uses a connector independent from control signals (see Figure 12, page 14).

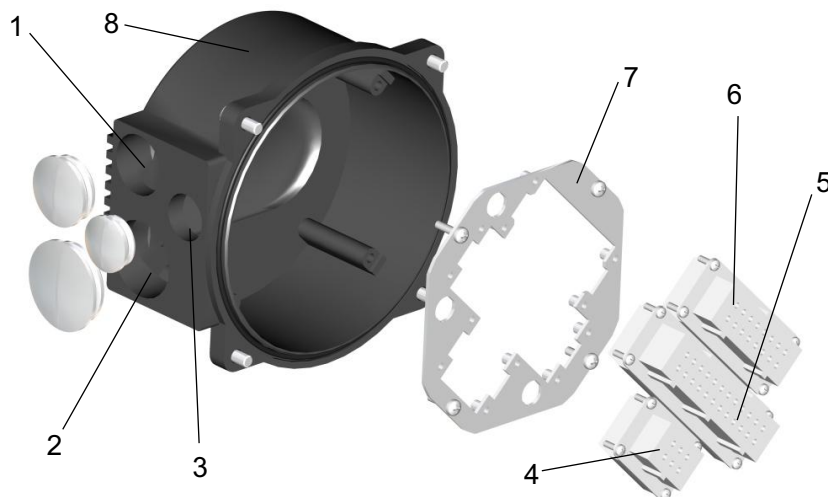

Figure 12: 1... Metric screw M32x1,5, 2... M40x1,5, 3... M25x1,5, 4... Plug insert Han6E (for power supply), 5... Plug insert Han24E (for control cables), 6... Connector for options, 7... Connector plate, 8... Connecting housing

5 Commissioning

The connection on **explosion-proof actuators** or, on special request also on non explosion-proof actuators) will be made via terminals (see Figure 13).

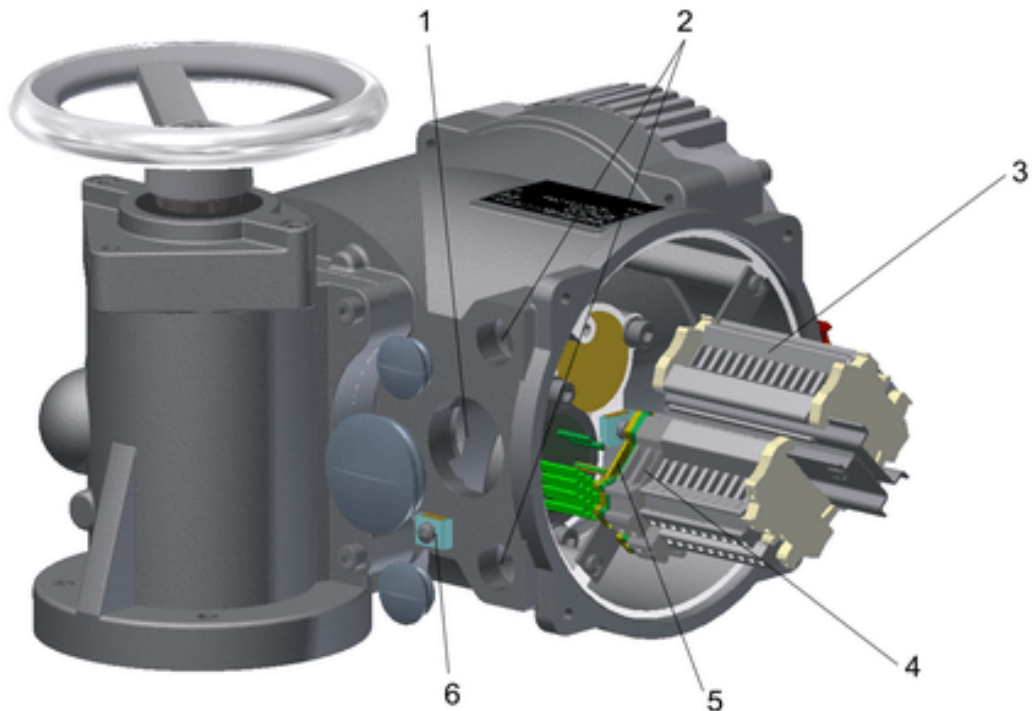

Figure 13: Terminal box: 1... Metric screw M40x1,5, 2... 2 pcs. M20x1,5, 3... Terminals for the control signals, 4... Terminals for the power supply, 5... Terminal for ground connection, 6... Outside ground connection

CAUTION: If, during outdoor installation, commissioning is not carried out immediately after electrical connection, the power supply must be connected at a minimum to achieve a heating effect. In this case, the silica gel may remain in the connection compartment until commissioning. See section 3.3, page 10.



CAUTION

5 Commissioning

Before commissioning, ensure that the actuator is correctly assembled and electrically connected (see section 4, page 11).

NOTE: Remove silica gel from the connection compartment.

5.1 General

CAUTION: During commissioning and after every disassembly of the actuator, the electric end positions (see section 5.6, page 17) must be reset.



CAUTION

5.2 Manual operation

The use of a differential gearbox in the handwheel assembly makes mechanical switching unnecessary during manual operation.

CAUTION: Manual operation with mechanical or electromechanical equipment (such as: lever, drilling machine, etc.) is **NOT ALLOWED**, as this may damage the product.



5.3 Mechanical default settings, preparation

The use of multi-turn sensors makes mechanical settings unnecessary.

CAUTION: Before the motorised operation of the valve, it is essential to check and eventually adjust torque settings.



5.4 Welcome Menu

The welcome menu presents the user a welcome message, and guides the user through some basic settings. Some basic settings include the language and the timezone. Please follow the instructions shown on the display. Please consult the *Operating Instructions for ACTUSMART Control Units, section Operation* for general information about operating the control unit.

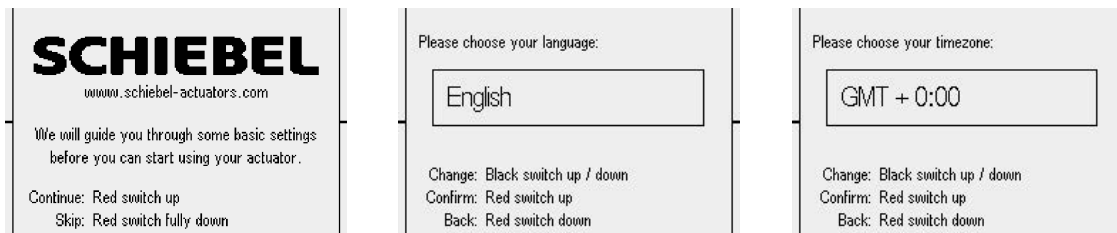

Figure 14: Welcome menu (1/2)

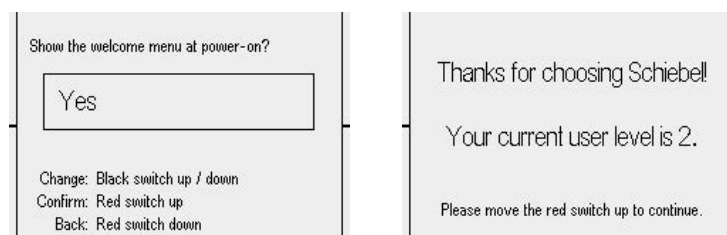

Figure 15: Welcome menu (2/2)

5.5 User Level and Permissions

In order to edit and/or show certain parameters, a user level with the necessary permissions has to be set as current user level. The current user level may be set temporarily in the "U User Level" menu item. It is also possible to set the default user level, which will be set as the current user level until set otherwise ("U User Level" or default user level). Please refer to the *Operating Instructions for ACTUSMART Control Units*, section Parameter group: User Level, for more information about the user levels.

5.6 End limit setting

A detailed description of the operation of the ACTUSMART CM controller can be found in the *Operating Instructions for ACTUSMART Control Units*.

NOTE: Please make sure, that the current user level has the permission to edit the end limits.

5.6.1 End limit OPEN

Set the selector switch and control switch to the center position.

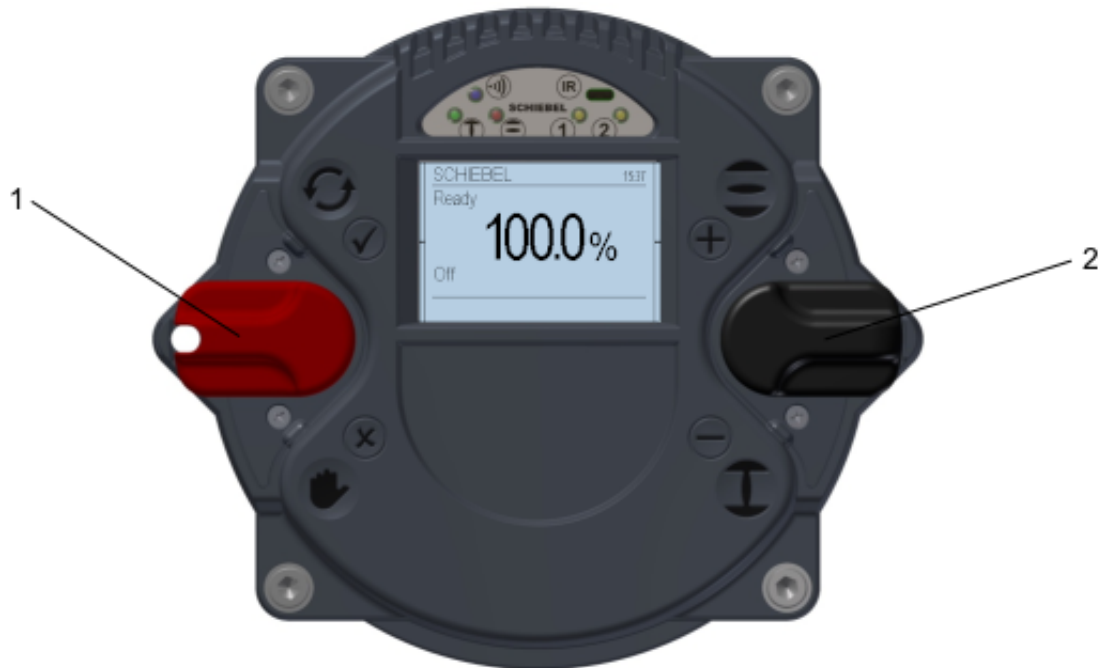

Figure 16: 1... Selector switch (red), 2... Control switch (black)

Scroll through the menu with the control switch. Move the control switch towards the first menu item ⊖ "P 1.1 End limit – Open".

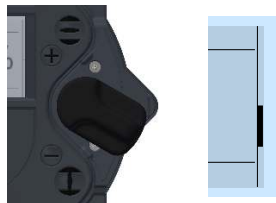

Figure 17

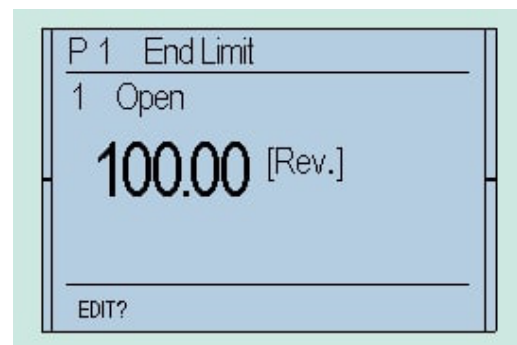

Figure 18

Afterwards, flip up the selector switch slightly and let it snap back to its neutral position ⊕.

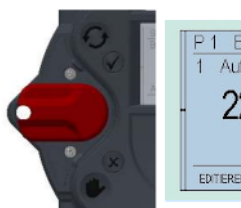

Figure 19



Figure 20

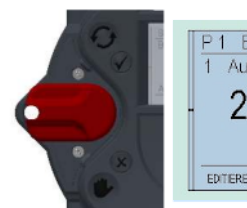

Figure 21

This changes the bottom line of the display from "EDIT?" to "SAVE?"

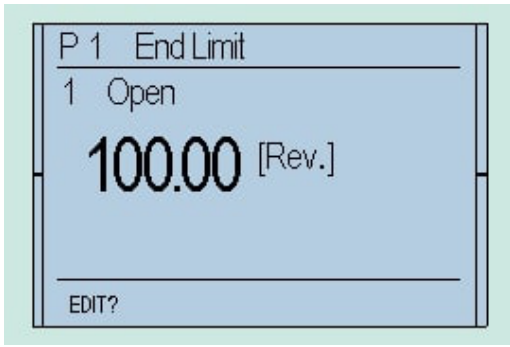

Figure 22

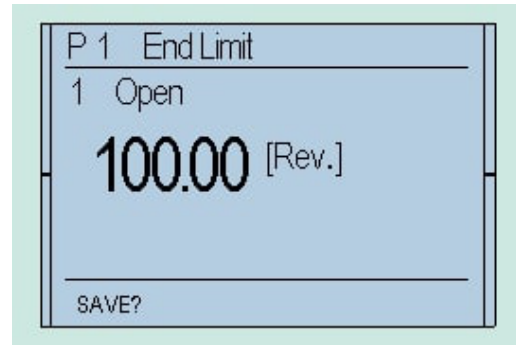

Figure 23

Then, push down the selector switch until it snaps into place. In doing so, the bottom right now on the display will show "TEACHIN" (⊗)

CAUTION: Once the display shows "TEACHIN", use the operating switch (black switch) to start the motorised operation of the actuator. In this mode, no travel-dependent switch off occurs in the end position.



CAUTION: Please note that, during motor operation, only torque monitoring remains active, as travel adjustment will happen subsequently. Therefore, please check beforehand whether the maximum torque has been already parameterised.



Absolute and relative values on the display will change continuously along with position changes.



Figure 24

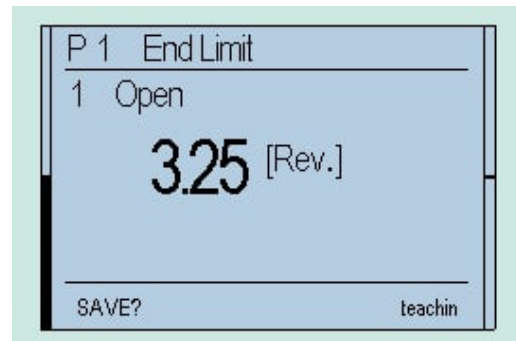

Figure 25

Manually move the actuator with the handwheel (see section 2.1, page 5, or section 2.7, page 7) or by motor via the operating switch (black switch) to the end position OPEN of the valve.

- Absolute value: Absolute value of the position feedback
- Relative value: The value to the other end position

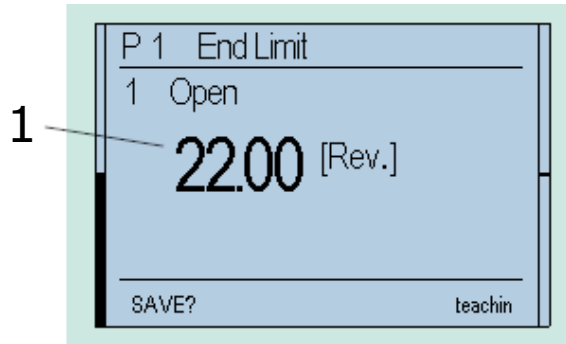

Figure 26: 1... Absolute value

When the desired end position OPEN of the valve is reached, move the selector switch back to the middle position. Thus, the line "TEACHIN" disappears.

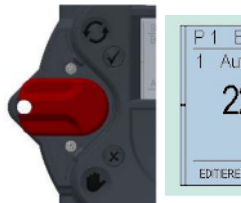

Figure 27

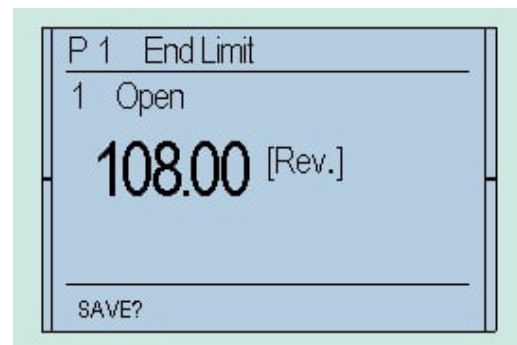

Figure 28

In order to confirm the end position (save), slightly flip up the selector switch towards ☑ and let it snap back to its neutral position.

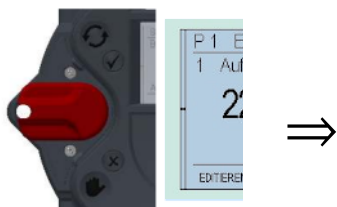

Figure 29



Figure 30

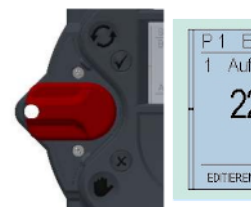

Figure 31

This changes the bottom line of the display for "SAVE?" to "EDIT?" and the end position is stored.

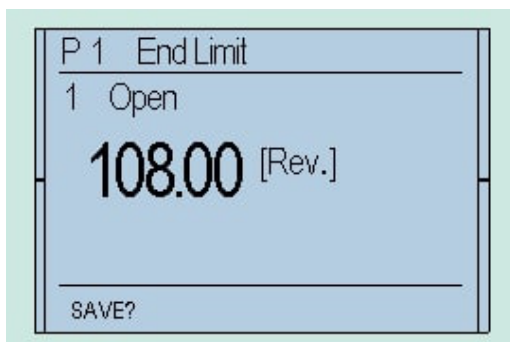

Figure 32

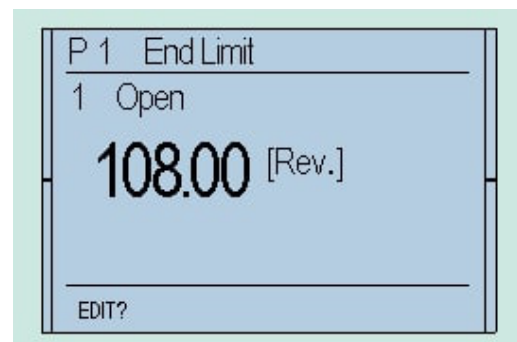

Figure 33

5.6.2 End limit CLOSE

Use menu item "P 1.2 End limit - End limit CLOSE" as for End limit OPEN

5.7 Final works

Following commissioning, check for proper sealing the covers to be closed and cable inlets (see section 2.5, page 7). Check actuator for paint damage (by transport or installation) and repair if necessary.

6 Maintenance

WARNING: Maintenance work on open actuators may only be conducted if these are de-energized. Reconnection during maintenance is strictly prohibited. Work on the electrical system or equipment must be carried out only in accordance with electrical regulations by a qualified electrician himself or by specially instructed personnel under the control and supervision of a qualified electrician.



WARNING

WARNING: The actuator shall not be installed in areas of strongly charge generating processes (see explosion protection sticker on figure 34). In addition, the equipment shall only be cleaned with an antistatic or damp cloth.



WARNING

WARNING: Do not open the control unit when an explosive gas atmosphere is present (see explosion protection sticker on figure 34)!



WARNING



Figure 34: 1... Explosion protection sticker

Actuators are ready for use after installation. By default, the actuator is delivered filled with oil.
On-going monitoring:

- Beware of increased running noise. During long downtime periods, operate the actuator at least every 3 months.
- For actuators with output types A, B and C according to DIN 3210-A, B1, B2 and C according to DIN ISO 5210, re-lubricate at least every 6 months on existing grease fittings (see section 11.3, page 26).

Actuators are designed for installation in any position (see section 2.6, page 7). Therefore, the main body is not equipped with a level indication or a drain plug.

The replacement of the lubricant from the main body must be performed via the handwheel.

Depending on the stressing subjected to, do the following approx. every 10,000 to 20,000 hours (about 5 years, see section 11, page 26):

- Oil change
- Replace seals
- Check all the roller bearings and the worm gear assembly and replace if necessary.

Take the types of oils and greases to be used from our lubricant table (see section 11, page 26).

NOTE: Check the cable glands at regular intervals (annually) for tightness of the cables and retighten if necessary.

If the visual inspection (eg. dust or water penetration) indicates that the effectiveness of the sealing elements of the cable entry has suffered damage or aging, such elements have to be replaced preferably by using the original spare parts from the manufacturer of the equipment or through cable entries of comparable quality as well as the same ex- or IP protection class.

If screws need to be replaced, it is preferable to use original replacement parts. The tensile strength of the screws must be at least 450 MPa (450 N/mm²)!

CAUTION: For explosion-proof actuators, specific parts may only be replaced by the manufacturer. Please also consult other relevant instruction manuals (e.g. Failsafe, gearbox, etc.).



CAUTION: In the case of explosion-proof actuators, repairs to the flameproof joints are **NOT** intended. If damage is found on the gap surfaces (control unit cover, motor shaft, sensor shaft, cable bushings), the device must be replaced!



7 Battery Replacement

WARNING: Certain parts of the actuator carry hazardous voltage levels. All work on the opened device is only permitted in a de-energized state. The device must not be switched on again during work!



WARNING

WARNING: The control unit must not be opened when an explosive gas atmosphere is present.



WARNING

In order to be able to maintain the function of the real-time clock as well as the counter readings of the controller even in a de-energized state, it has a button cell battery. The service life of this battery varies depending on the ambient conditions, and must be replaced if necessary, at the latest as soon as the control unit issues the relevant warning (see *Operating Instructions for ACTUSMART Control Units*).

The expected service time for the battery is 10 years. For replacement, pry the battery out of the socket using a plastic lever tool. Make sure that the tool is not placed under the socket, as this may cause damage to the circuit board.

CAUTION: When choosing a replacement battery, it is necessary to use specific models, to meet the requirements for explosion-proof actuators. Please contact the manufacturer for more information about the battery or consult the list below, when a battery replacement is due.



CAUTION

Following battery models are used:

Renata CR2032

- Ex-Type¹⁾ : 0, 1, 2
- Electrochemical System: MnO₂/Li
- Nominal Voltage: 3V
- Rated Capacity: 235mAh
- Operating Temperature: -40... +85°C

Murata CR2032W

- Ex-Type¹⁾ : 0, 1, 2, 5, 6
- Electrochemical System: MnO₂/Li
- Nominal Voltage: 3V
- Rated Capacity: 210mAh
- Operating Temperature: -40... +125°C

Murata CR2032X

- Ex-Type¹⁾ : 0, 1, 2
- Electrochemical System: MnO₂/Li
- Nominal Voltage: 3V
- Rated Capacity: 220mAh
- Operating Temperature: -40... +85°C

¹⁾See Model Code, digit **D** in section 2.2 on page 6

8 Troubleshooting

Upon warning or error, the bottom line of the display will show the corresponding plain text description. This event will also be entered into the history (see *Operating Instructions for ACTUSMART Control Units, section Troubleshooting*).

9 Fuses

WARNING: Certain parts of the actuator carry hazardous voltage levels. All work on the opened device is only permitted in a de-energized state. The device must not be switched on again during work!



WARNING

WARNING: The control unit must not be opened when an explosive gas atmosphere is present.



WARNING

The Logik board of the controller cover (see Figure 35, page 25) features two miniature fuses for the control lines.

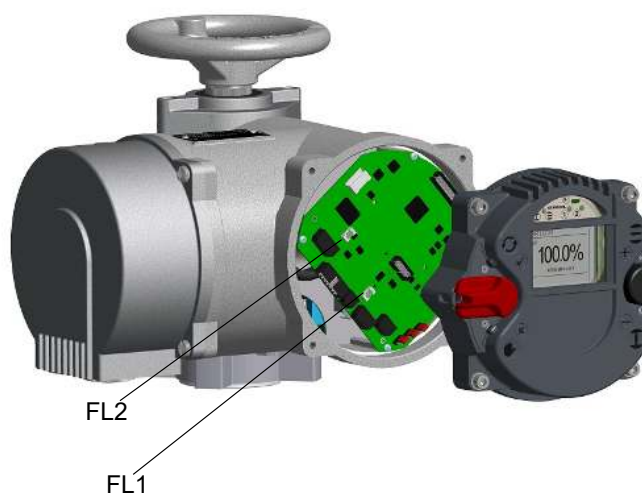

Figure 35: FL1... fuse for auxiliary supply, FL2... fuse for the binary outputs

Fuses on the logic board

Fuse	Value	Manufacturer	No. of spare parts
FL1	1AT	Littelfuse 454 NANO ² Slo-Blo [®] slow	FUSE-F1
FL2	4AT	Littelfuse 454 NANO ² Slo-Blo [®] slow	FUSE-F2

NOTE: The frequency inverter is protected by an input fuse and the explosion-proof version also has a thermal fuse (see section 2.8.3, page 8).

10 Spare parts

When ordering spare parts, please provide us with the serial number of the actuator (see section 2.3, page 6). Check the separate break-down image and separate list of spare parts.

CAUTION: Only original spare parts shall be used to replace faulty components. As for the control unit cover, screws with a minimum yield stress of 450 MPa (450 N/mm²) shall be used for the closing of the flameproof enclosure.



CAUTION

11 Lubricant recommendation, lubricant requirements

CAUTION: Please note, that safety precautions such as the use of personal protective equipment (PPA) may have to be followed! Please consult the safety datasheet (in section 8) of the product in question.



CAUTION

11.1 Main body: -25 to +70 °C

Operating oil: DIN 51 517-CLP-HC

i.e. fully synthetic high-performance gear oils based on poly-alpha-olefins (PAO)

Viscosity class:	320 ISO VG
Pourpoint:	< -39 °C (according DIN ISO 3016)
Lubricant requirement CM12:	600... 650 ml
Lubricant requirement CM25:	800... 850 ml

11.2 Main body: -40 to +70 °C

Operating oil: DIN 51 517-CLP-HC

i.e. fully synthetic high-performance gear oils based on poly-alpha-olefins (PAO)

Viscosity class:	68 ISO VG
Pourpoint:	< -54 °C (according DIN ISO 3016)
Lubricant requirement CM12:	600... 650 ml
Lubricant requirement CM25:	800... 850 ml

11.3 Output type A, spindle drives (linear actuators) and Failsafe actuators: -20 to +70 °C

Grease DIN 51502-K(P) R -40

i.e. water repellent complex grease on Al-soap base with high resistance to acids and alkalis

Penetration 0.1 mm:	310 - 340
Dropping point:	about 260 °C
NLGI No.:	1
acid-free, little or not water-reactive	

11.4 Output type A, spindle drives (linear actuators) and Failsafe actuators: -40 to +70°C

Grease DIN 51502-K(P) K -60

i.e. water repellent complex grease on Li-soap base with high resistance to acids and alkalis

Penetration 0.1 mm: 265 - 295

Dropping point: > 200 °C

NLGI No.: 2

acid-free, little or not water-reactive

11.5 Basic lubricant service interval

NOTE: Schiebel actuators must be serviced 10 years after delivery by SCHIEBEL Antriebstechnik GmbH, A-1230 Vienna. The functionality and durability of the lubricant is however contingent upon the operating conditions. Where applicable, reduction factors must be considered.

Operating condition (s)	Definition	Reduction factor (multiplier)
Duty time DT	(Total engine running time)	
Extremely high DT	over 1250 hours/year	0.5
High DT	over 500 hours/year	0.7
Extremely low DT	less than 0.5 hours/year	0.8
Ambient temperature	(permanent or long-term)	
Extremely changeable	between -10 and +50 °C	0.5
Extremely high	above +50 °C	0.7
Extremely low	below -25 °C	0.9
Output speed	(on actuator main shaft)	
High speed	over 80 rpm	0.8
Utilisation	(relative to rated power)	
Very high	over 90%	0.8
High	between 80 and 90%	0.9

Application example:

Extremely low DT + extremely low ambient temperature + high speed + 87% utilization

*⇒ 0.8 * 0.9 * 0.8 * 0.9 = 0.51 reduction factor*

*Lubrication maintenance interval ⇒ 10 years * 0.51 = 5.1 years (62 months).*

CAUTION: This calculated maintenance interval does neither apply to the maintenance of output type A (threated bushing) units nor to the maintenance of linear and spindle drive units. These units must be periodically lubricated (at least every 6 months) via the grease nipples (see section 11.3)!



CAUTION

During maintenance of our actuators, remove and replace old grease with new one. **Mixing of different lubricant types is NOT permitted.** Quantities needed for lubricant service are listed in section 11, page 26.

12 Training

NOTE: If you experience problems during installation or upon adjustments on site, please contact SCHIEBEL, Vienna at +43 (1) 66 108 or via the Internet at www.schiebel-actuators.com to prevent any operational errors or damage to the actuators. Schiebel recommends engaging only qualified personnel for installation of Schiebel actuators. Upon special request of the client, SCHIEBEL can conduct training on the activities listed in this operating manual at the factory of SCHIEBEL.

13 Original Declaration of Incorporation of Partly Completed Machinery

According Machinery Directive 2006/42/EC (Annex II, sub. B)

The manufacturer, the company:

SCHIEBEL Antriebstechnik Gesellschaft m.b.H.
Josef-Benc-Gasse 4
A-1230 Vienna

hereby declares that for the partly completed machinery described below:

Electric actuators series:

CM	rCM	exCM	exrCM
-----------	------------	-------------	--------------

the following basic requirements of the Machinery Directive (2006/42/EC) are applied and fulfilled:

Annex I,	articles	1.1.2, 1.1.3, 1.1.5; 1.2.1, 1.2.1, 1.2.2, 1.2.6; 1.3.1, 1.3.2, 1.3.7; 1.5.1; 1.6.3; 1.7.1, 1.7.3, 1.7.4
----------	----------	--

The following European harmonized standards have been applied:

EN 12100:2010		
EN ISO 5210:1996	EN ISO 5211:2001	DIN 3358:1982

The relevant technical documentation for partly completed machinery referred to in Annex VII, Part B has been prepared. The manufacturer commits to electronically submitting the documents for the incomplete machine to the competent national authority upon request.

For the preparation of the technical documents is authorized:

Head of mechanical Engineering
Schiebel Antriebstechnik Gesellschaft m.b.H.
Josef-Benc-Gasse 4
A-1230 Vienna

This partly completed machinery must not be put into service until the final machinery into which it is to be incorporated has been declared in conformity with the provisions of the Machinery Directive 2006/42/EC, where appropriate.

The electric actuators as partly completed machinery are in conformity with the relevant regulations of the EU directives:

Directive 2014/30/EU ("EMC-Directive")
Directive 2014/35/EU ("Low voltage directive")
Directive 2014/34/EU ("ATEX-Directive") for correspondingly marked devices

The corresponding separate EC Declarations of Conformity are valid.

Vienna,
(location)

Mar. 13th, 2018
(date)



.....
(Klaus Schiebel, general manager)

14 Declaration of Conformity

(Ex directive, EMC directive and Low voltage directive)

The producer:

SCHIEBEL Antriebstechnik Gesellschaft m.b.H.
Josef-Benc-Gasse 4
A-1230 Wien

herewith confirms that the equipment

electric actuators with integrated control unit model Actusmart and following types

ex(r)CM12	⊕ II 2 G Ex db eb II C T4 Gb	TPS 23 ATEX 112599 0002 X	IECEX TPS 23.0013 X
ex(r)CM12FS	⊕ II 2 G Ex db eb II B T4 Gb	TPS 23 ATEX 112599 0002 X	IECEX TPS 23.0013 X
ex(r)CM25	⊕ II 2 G Ex db eb II C T4 Gb	TPS 23 ATEX 112599 0002 X	IECEX TPS 23.0013 X

meets the requirement of the directive:

2014/34/EU

EC Directive for Operation of Equipment in Potentially Explosive Atmospheres

and complies with the following harmonised standards in the version valid at signature date:

EN IEC 60079-0:2018

EN IEC 60079-7:2015/A1:2018:2014

EN 60079-1:2014

EN 60079-31:2014

For the above listed actuators, a type examination certificate TPS 23 ATEX 112599 0002 X and IECEx TPS 23.0013 X, issued by TÜV SÜD Product Service GmbH is available. The following notified bodies certify the conforming type:

**TÜV SÜD Product Service
GmbH**

D-80339 Munich

NB 0123: Type examination
certification

Furthermore, they are consistent with the directive

2014/30/EU („EMC directive“)

in consideration of the respective operating instructions, and the fulfilment of the Directive has been demonstrated by the following standards:

EN IEC 61000-6-2:2019

EN IEC 61000-6-3:2021

EN IEC 61000-6-4:2019

EN IEC 61000-3-2:2019+A1:2021

EN 61000-3-3:2013+A1:2019

and are also consistent with the directive:

2014/35/EU („Low voltage directive“)

in consideration of the respective operating instructions, and the fulfilment of the Directive has been demonstrated by the following standards:

IEC 60204-1:2005 + A1:2008

EN 60529:1991 + A1:2000

Vienna,
(location)

November
24th.2023
(date)



.....
(Klaus Schiebel, general manager)

Vienna,
(location)

November
24th.2023
(date)



.....
(Udo Klimpfinger, explosion protection officer)

15 Technical data

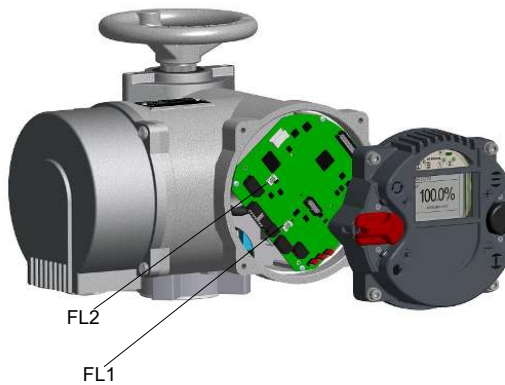

Figure 36: Control unit

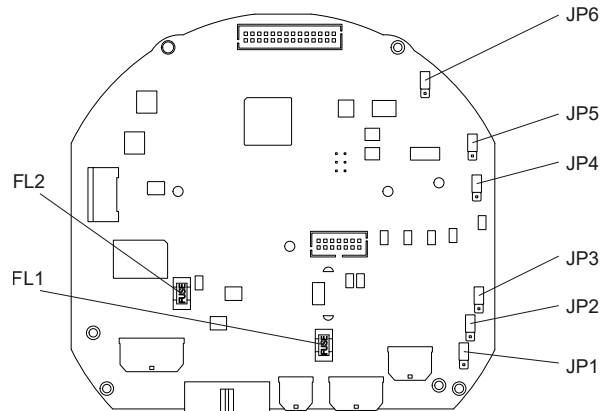

Figure 37: Logik board

15.1 Binary outputs

Count:	8
Power supply:	24 VDC nominal range: 11...35 VDC (either from internal or external)
Max voltage drop at set output:	1 V
Output voltage at non-set output:	<1 V
Maximum current per output:	500 mA (short circuit proof)
Maximum permissible total current for all outputs:	4 A
Fuse (Fuse FL2, see Figure 37, page 31):	4 A slow (Littelfuse 454 NANO ² Slo-Blo [®])

Binary outputs with external supply are separated from other controllers via optocouplers.

It is allowed to connect binary outputs in parallel. If the outputs have the same setting, the current of each output may be added together. If the settings of the outputs are different, a hardwired logical OR is realized.

15.2 Binary inputs

Count:	5
Nominal voltage:	24 VDC towards common ground
Voltage for input set:	>10 V (8.5 V typ.)
Voltage for input not set:	<7 V (8.5 V typ.)
Maximum voltage:	30 VDC
Current consumption at 24 VDC:	10.5 mA typ.

Binary inputs are separated from other controllers via optocouplers.

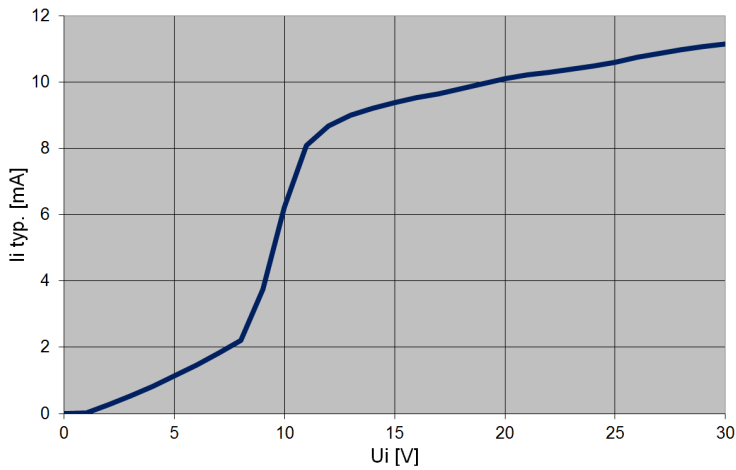

Ui ... Input voltage
 Ii ... Input current

Figure 38: Binary inputs, input characteristic

Jumpers JP1 ... JP3 can be used to interconnect the binary inputs to groups with separate earths:

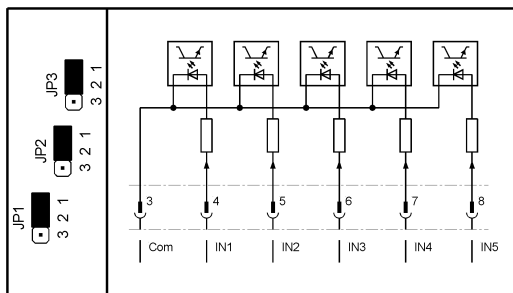

Figure 39: 5 inputs with same common

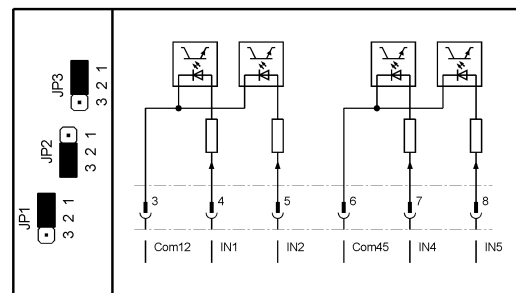

Figure 40: 2 separated groups of 2 inputs with same ground
 Input IN3 is disabled.

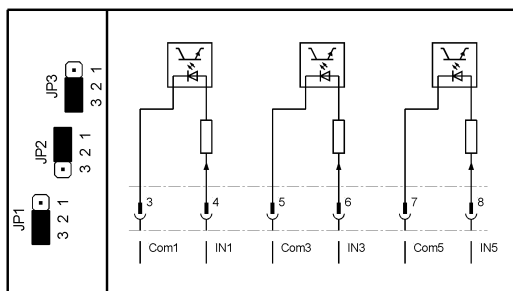

Figure 41: 3 separated inputs
 Inputs IN2 and IN4 are disabled.

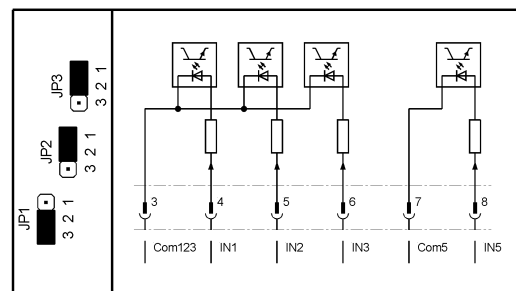

Figure 42: 3 inputs with same common and 1 separated input.
 Input IN4 is disabled.

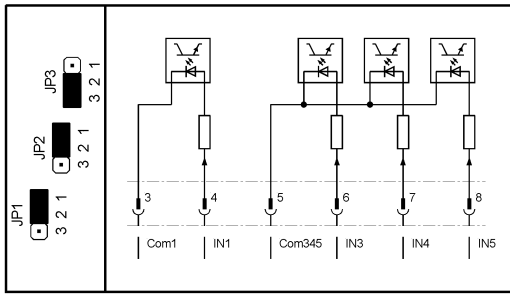

Figure 43: 1 separated input and 3 inputs with same common.
Input IN2 is disabled.

Examples:

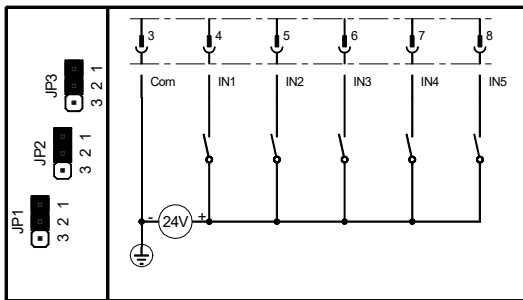

Figure 44: 5 inputs with common = "-" using external 24V

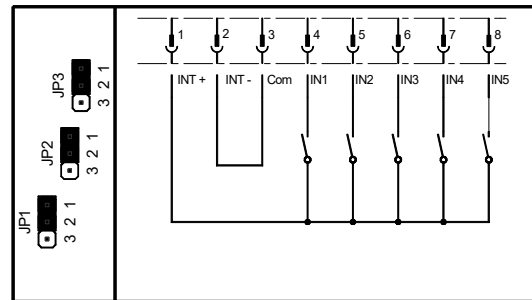

Figure 45: 5 inputs with common = "-" using internal 24V (e.g. for dry contacts)

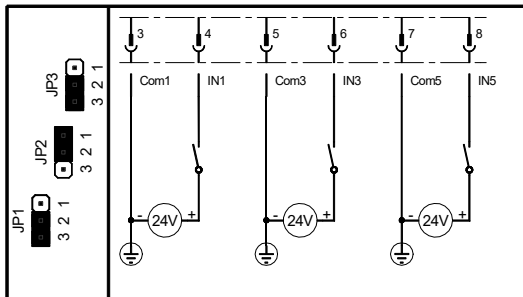

Figure 46: 3 separated inputs using 3 separated external 24V

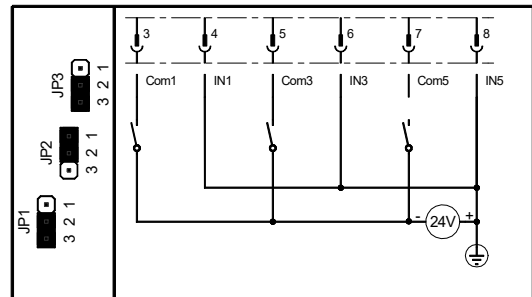

Figure 47: 3 separated inputs with common = "+" using external 24V

15.3 Analog inputs

Input 1: setpoint value

- Current range: 0...25 mA
- Resolution: 14 bit
- Accuracy: 0.5%
- Input resistance: 60 Ω

Analog input 1 is electrically isolated from the rest of the electronic system.

Input 2: External actual value (only in combination with PID controller)

Current range: 0...20.8 mA
 Resolution: 12 bit
 Accuracy: 0.5%
 Input resistance: 120 Ω

Jumper JP6 can be used to switch analog input 2 from a passive input (default) to an input with internal 24 V power supply (for 4...20 mA, two-wire transmitters).

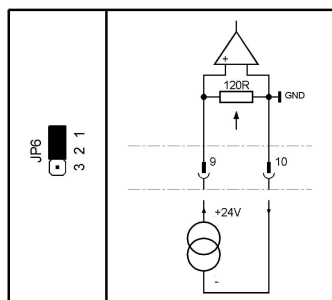

Figure 48: Passive input (default)

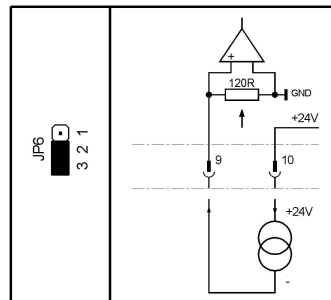

Figure 49: Input with internal supply (active input)

NOTE: The analog input 2 is referenced to common of the electronic system and the auxiliary power supply (see section 15.5).

15.4 Analog output

Current range: 0...20.8 mA
 Resolution: 12 bit
 Accuracy: 0.5%
 Max load: 600 Ω

The analog output is galvanically isolated from the rest of the electronic system.

Jumper JP4 can be used to switch the analog output from an active power source (default) to a current sink, allowing the output to simulate a 4...20 mA, two-wire transmitter.

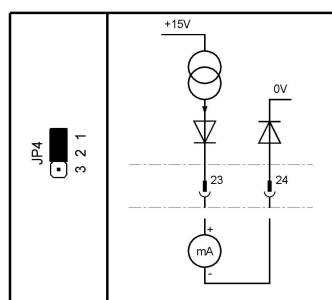

Figure 50: Current source

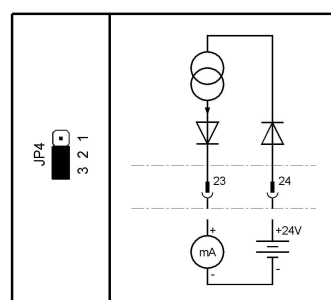

Figure 51: Current sink

Ground potential is the potential of the control unit and the auxiliary supply (see chapter 15.5).

15.5 Auxiliary voltage input and output

Input voltage range (auxiliary voltage input):	20... 30 VDC
Maximum current consumption (auxiliary voltage input):	500 mA
Maximum current consumption in power-save mode (auxiliary voltage input):	120 mA
Output voltage (auxiliary voltage output):	typ. 23 V
Maximum output current (auxiliary voltage output):	200 mA
Resistance of common ground vs. earth:	typ. 500 kΩ
Resistance of common ground vs. earth (floating version):	> 10 MΩ
Capacitance of common ground vs. earth:	typ. 100 nF
Maximum allowed voltage of common ground vs. earth:	max. 40 Vs
Fuse (Fuse FL1, see picture 37, page 31):	1 A slow (Littelfuse 454 NANO ² Slo-Blo [®])

Ground potential is the common ground of the controller and the analog inputs and outputs.
 The auxiliary voltage output can be set in menu P6.5.

The power-save mode is defined as follows:

- No power supply (the controller is powered exclusively through the 24 V auxiliary voltage input).
- The backlight of the LCD display switches off automatically.
- No additional hardware options included (Profibus Interface, DeviceNet interface, relay board, etc. ...).
- Binary outputs and the mA output are not enabled; when activating, the respective currents must be added to the total current consumption.

15.6 Connections

15.6.1 Connections for non explosion-proof version

Power/motor:	Industrial plug with 6 pins Screw connection 16 A, max. 2.5 mm ² , AWG14
Control signals:	Industrial plug with 24 pins Screw connection 16 A, max. 2.5 mm ² , AWG14

Optionally, contacts are available in crimp or cage clamp designs.

15.6.2 Connections for explosion-proof version

Power/motor:	terminals with screw connection 16 A, 0.5... 4 mm ² , AWG20... AWG12
Control signals:	terminals with screw connection 4 A, 0.5... 2.5 mm ² , AWG20... AWG14

15.7 Miscellaneous

Ambient temperature:

non explosion-proof version:	-25 ... +60 °C
explosion-proof version:	-20 ... +40 °C (according EN 60079-0)
ex version with extended temperature range:	-40 ... +70 °C
exCM12 FS with extended temperature range:	-40 ... +60 °C

Protection according to EN 60529: IP67

Standard colour: RAL7024

NOTE: If the actuator is exposed to excessive UV-light, colour deviations of the painting might occur.

16 Technical data CM12

The motor (brushless DC motor) is controlled via integrated power electronics, which also provide the supply voltage for the controller.

16.1 Standard version CM12

Output torque:	max. 125 Nm
Average permissible output torque:	max. 40 Nm
Setting range of tripping torque:	32 ... 125 Nm
Setting range of output speed:	1.0 ... 70 min ⁻¹
Travel range:	max. 300 revs / 1600 revs
Reduction ratio handwheel:	2,5
Output resolution:	about 0.25° / 0.75° / 0.25°
Supply voltage range AC:	110 ... 240 Vrms +/-10%, 50/60 Hz
Nominal current (40 Nm / 70min ⁻¹):	3,8 A / 230 VAC
Idle power consumption:	12 W typ., 24 W max.
Weight:	23.8 daN

Idle power consumption is measured with an idle motor and is dependent on the existing hardware options.

17 Technical data CM25

The motor (brushless DC motor) is controlled via integrated power electronics, which also provide the supply voltage for the controller.

17.1 Standard version CM25

Output torque:	max. 250 Nm
Average permissible output torque:	max. 75 Nm
Setting range of tripping torque:	64 ... 250 Nm
Setting range of output speed:	1.0 ... 32 min ⁻¹
Travel range:	max. 1600 revs
Reduction ratio handwheel:	2,5
Output resolution:	about 0.25° / 0.75° / 0.25°
Supply voltage range AC:	110 ... 240 Vrms +/-10%, 50/60 Hz
Nominal current (75 Nm / 32min ⁻¹):	3,8 A / 230 VAC
Idle power consumption:	12 W typ., 24 W max.
Weight:	30.5 daN

Idle power consumption is measured with an idle motor and is dependent on the existing hardware options.

18 Characteristic curves

18.1 Characteristic curves - CM12

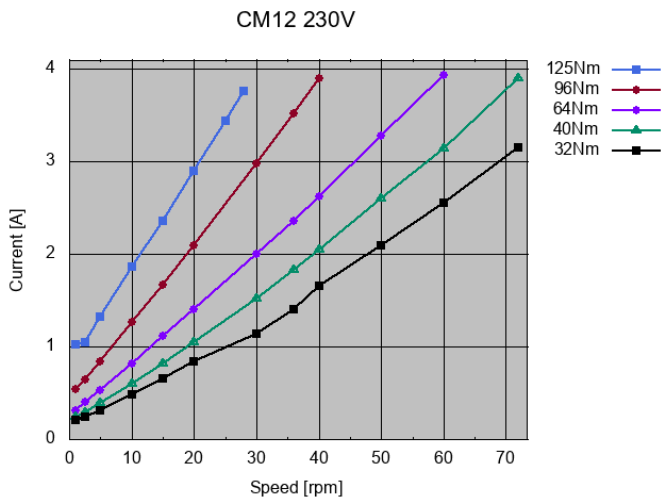
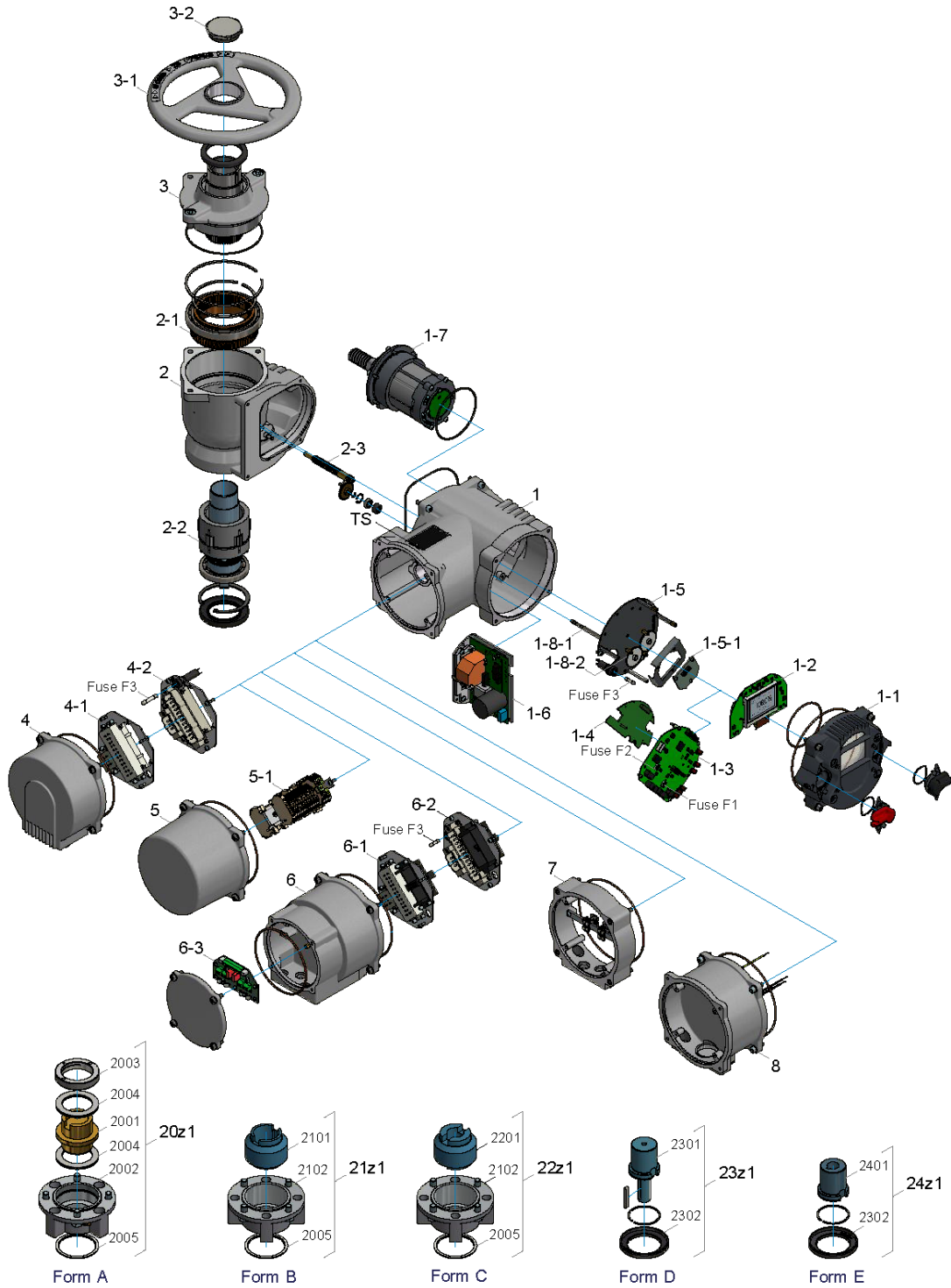

Figure 52: Current draw of the standard version

Spare parts ACTUSMART (ex)(r)CM12.V1.2



CAUTION: When ordering spare parts, you **must** provide the **serial number** (look type shield or status menu S6).



Use only original spare parts supplied by SCHIEBEL. Using other parts will render the warranty void. Illustrations may differ from actual spare parts.

Asm.	No.	Description
1		E-case
	1-1	Control unit cover
	1-2	Display circuit board
	1-3	Logic circuit board
	Fuse-F1	Micro fuse 1A
	Fuse-F2	Micro fuse 4A
	1-4	Expansion board (bus, relay)
	1-5	Multiturn sensor assembly
	1-5-1	Multiturn sensor
	1-6	BLDC
	Fuse-F3	Fuse 10AT
	1-7	Motor
	1-8-1	Sensor shaft
	1-8-2	Gear
2		Mech. case
	2-1	Worm gear
	2-2	Output shaft
	2-3	Helical cut pinion gear
3		Handwheel assembly
	3-1	Handwheel
	3-2	Screw plug
4		Plug cover
	4-1	Plug frame customer side (socket)
	4-2	Plug frame actuator side (pins)
5		Terminal box cover
	5-1	Terminal block
6		Entire bus plug cover with plugs & circuit board
	6-1	Bus plug frame customer side (socket)
	6-2	Bus plug frame actuator side (pins)
	6-3	Bus connection board
7		Additional ring bus (Ex)
8		400V module
TS		Type plate

Asm.	No.	Description
20z1		Output form "A" assembly G0/F10
	2001	Threaded spindle nut
	2002	Flange "A"
	2003	Ring nut
	2004	Bearing assembly
	2005	Centering ring F10
21z1		Output form "B" assembly G0/F10
	2101	Std "B" socket
	2102	Std flange "B"
	2005	Centering ring F10
22z1		Output form "C" assembly G0/F10
	2201	Std claw coupling "C"
	2102	Std flange "B"
	2005	Centering ring F10
23z1		Std output form "D" assembly G0/F10
	2301	Output shaft D Ø20mm
	2302	Centering ring G0
24z1		Std output form "E" assembly G0/F10
	2401	Output shaft E Ø20mm
	2302	Centering ring G0

**schiebel
-actuators
.com**

SCHIEBEL

SCHIEBEL Antriebstechnik
Gesellschaft m.b.H.
Josef-Benc-Gasse 4
A-1230 Wien
Tel.: +43 1 66 108 - 0
Fax: +43 1 66 108 - 4
info@schiebel-actuators.com
www.schiebel-actuators.com